

The Corporate Structure Amplifier

P Moore, Managing Director, Milmega Ltd

When developing an amplifier topology a number of divergent requirements vie for attention. Electrical specifications, mechanical specifications, reliability and maintainability requirements are all tossed into the mix, in search of the most effective balance in what is known as the life cycle cost equation – i.e. the delicate balancing of both acquisition and maintenance costs.

In first choosing an amplifier topology, Milmega looks to enhance its reputation for:

1. Technical Leadership – developing new products that ensure the best power density around i.e. delivering the most effective solution available rather than simply overwhelming a problem with power devices.
2. Flexibility – deriving topologies that allow the Customer to upgrade their amplifiers in power or frequency, as their budgets and operating requirements grow.

The favoured amplifier topology at Milmega is the Corporate Structure Amplifier, or CSA, (1). It derives its name from the hierarchy of levels employed in its construction, which, ignoring the combining elements, gives the block diagram of the amplifier an appearance not dissimilar to that of a rotated company organisational chart (see Figure 1).

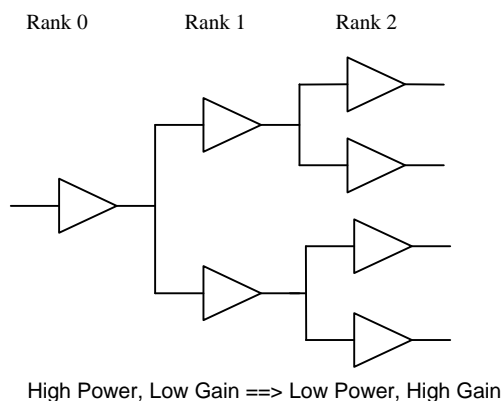

Figure 1: Corporate Structure Amplifier Schematic

The usual form of a CSA (2) employs identical unit amplifier designs, within each level, or rank, of the hierarchy but these designs may vary from rank to rank. Typically a lower power, high gain unit amplifier (a pre-amplifier) is employed at the front

end of the amplifier system with higher power, lower gain units (High Power Amplifiers, HPA's) being employed towards the output. At Milmega the amplifier units take the form of modules. Within each module design, the concept of the CSA is also employed at transistor level.

A key design goal is to reduce the number of different modules being utilised by developing modules with a high fan out capability, i.e. with sufficient output power to drive the loading of successive ranks, containing identical modules. Reducing the number of module types has the following important advantages:

1. From a development perspective, a high percentage of engineering cost can be budgeted for the development of one, or two, standard module designs with electrical, mechanical, thermal, reliability and manufacturing requirements the subject of a concentrated development focus.
2. Figure 2 shows the practical implementation of a 100W, 1-2GHz amplifier system, showing the low power, high gain pre amplifier driving four high power, lower gain HPA's in parallel. The pre-amplifier module is capable of driving 16 HPA's in parallel (allowing for combiner / splitter losses)

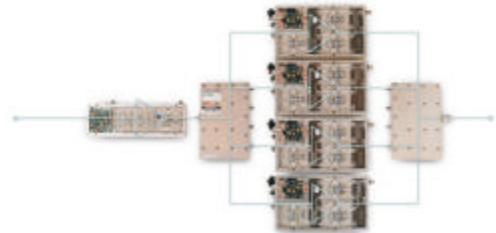

Figure 2: Practical implementation of a 100W, 1-2GHz CSA

3. From a reliability perspective, the multiple use of identical modules forces an inherent robustness into the amplifier system, as common assembly and test methods ensure repeatability of design throughout the manufacturing process. Milmega amplifiers regularly achieve 44,000 hours of 24/7³ usage before a module will fail. In amplifiers with more than 8 HPA's in the output rank, the effect of a single failure becomes increasingly negligible⁴. For example in a Milmega 0.8-2.2GHz, 400W amplifier



Ryde Business Park, Nicholson Road, Ryde,
Isle of Wight, PO33 1BQ, UK
Te: +44 (0)1983 618 004 Fax +44 (0)1983 811 521
Sales@milmega.co.uk www.milmega.co.uk

with 16 HPA's in the final rank, the loss of one HPA will only result in a power loss of 0.56dB, allowing continuing operation of the amplifier until the user schedules a repair slot. Typically it will be a single transistor that fails, with an associated power loss of 0.14dB for a 16 HPA output rank, with 4 paralleled transistors in the output of each HPA.

4. From a maintainability perspective the use of identical modules, and therefore by default the reduction of complexity, reduces spares holding and greatly simplifies the maintenance activity. Power supply design and distribution, control philosophy and implementation and physical construction are greatly simplified. A Milmega amplifier can have a module replaced, by a suitably trained Customer, and be back on line within a 2-hour period.

5. From an amplifier power upgrade perspective, if an element of redundancy is built into the fan-out capability of the pre-amplifier module then the existing amplifier system can easily be upgraded in power by simply adding power modules to the final HPA rank. This concept is shown in Figure 3 where a Milmega 1-2GHz, 55W, is upgraded first to 100W, then to 250W, by the simple addition of two additional HPA modules and then a further four HPA's (with the appropriate combining structure losses factored for).

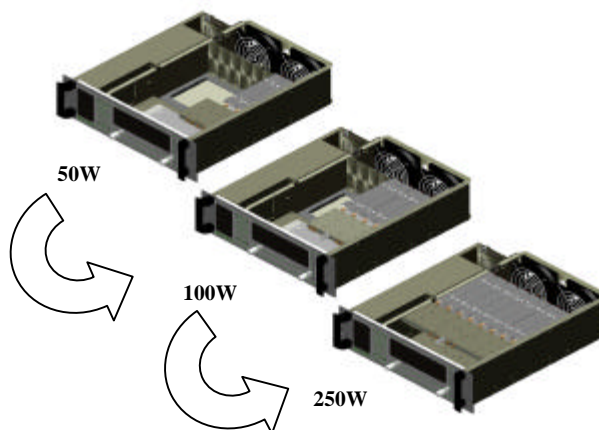

Figure 3: Ease of Upgrade with a CSA Topology

Conclusion

How an amplifier system is partitioned, is a design decision that can have profound consequences on the acquisition cost, as well as the cost of maintaining or upgrading, an amplifier during its service life. Getting the decision wrong at the concept stage can easily tip the balance in favour of one particular cost. System level partitioning decisions can therefore only be made after careful analysis of Customers reliability and maintainability requirements. Milmega regularly employs the Corporate Amplifier Structure [CSA] topology to deliver technical superiority coupled with class leading reliability and a simple upgrade path.

¹ The term, and the basis for this application note, is taken from the book by Edward D. Ostroff et al. Entitled "Solid State Radar Transmitters", Artech House, 1985, ISBN 0-89006-169-6

² A special case of the CSA is the UCSA (Uniform Corporate System Amplifier) in which all unit amplifiers are identical within all ranks.

³ I.E. 24 hours a day, 7 days a week

⁴ For the output rank of a CSA, the percentage of failures is related to the power output reduction, in dB, as follows: Power Loss = $10\text{Log}[N_s / N_o]^2$ dB where N_s is the number of surviving modules and N_o is the original number of modules in the output rank.